

---

---

# THE "LIGHT SHAFT"

---

---

April 2022

---

---



## THE FIRST NATIONAL AUSTIN 7 RALLY

1972

Started at Old Melbourne  
Motor Inn

Then to Emu Bottom  
Homestead

See Story Page 6



**AUSTIN 7 CLUB INC. Reg No. A0003290N**  
**P.O. BOX 462**  
**MOORABBIN VIC 3189**  
**<http://www.austin7club.org/>**

Facebook <http://www.facebook.com/Austin-7-Club-Inc-1544252182541126/>



## **Austin Seven Clubs Association**

### **The Online Archive**

Handbooks, Parts Books, Body Parts Book and lots more.

Just download it to your computer - all part of our membership of the Association.

More being constantly added.

These references are a great way to identify parts for your Austin7.

Also it may help to determine the year of the various parts.

***An original Parts Book, for your model is one of the most valuable resources, especially for remote members.***

***An original Handbook is also a handy reference.***



**Magazine of the Austin 7 Club Inc. In its 73rd year  
Foundation Patron of the Club**

**Col. A C R Waite,(dec.) MC, OStJ, DL, JP, Freeman of the  
City of London 1894—1991., Life member of the British Racing Drivers Club.  
Winner of the first Australian Grand Prix.**

### **CALENDAR OF EVENTS**

*Continued on Page 4*

***NOTE: - Attendance at indoor Club Events is subject to  
ALL attendees producing a valid current COVID-19  
Certificate***

### **CALENDAR OF EVENTS Cont.**

#### **APRIL**

6	Wed	7	A	MGM / Spares
<b>9/14</b>		<b>7</b>		<b>Austin 7 National Rally</b>
15	Fri			VDC Hot Cross Bun Picnic Run – Braeside Park
15/18				Easter
20	Wed	7	A	HAS / Spares

*Continued on Page 4*

#### **LIGHTSHAFT COPY CLOSING**

Copy for Lightshaft **closes** late on

***Tuesday 19 April 2022.***

**MAY**

1	Sun	7		OST 1
			S	V.H.R.R. Rob Roy
	Sun			Gippsland Vehicle Collection Swap Meet
4	Wed	7	A	MGM / Spares
7	Sat	7		Spares / BBQ
8	Sun			Mother's Day
14	Sat			Club hire – Janne's All Day Craft Day <i>Austin 7 Heaven Workshop</i>
15	Sun			OST 2
18	Wed	7	A	HAS / Spares
27	Fri	7		<i>Benalla Historic Vehicle Tour</i>
<b>27-29</b>	<b>Fri-Sun</b>	<b>7</b>	<b>AR</b>	<b>Historic Winton</b>

The Club's Meeting and Spares Days will recommence, but with an expectation that everyone will "socially distance" and applicable COVID-19 Rules will be respected and enforced.

***Only visit the Clubrooms if you have a current COVID-19 Certificate.***

***Social distancing rules apply which will limit number of attendees***

***Spares Hours Saturday - 12:00 Noon to 2:30pm***

***Spares Hours for MGM. - 7:30pm to 8:00pm sharp***

***Spares Hours for Hot Air Session. - 7:30pm to 9:00pm sharp***

## PRESIDENT'S REPORT

April is the start of two months of “all you can get “ in the world of Austin 7s. As we all know we start with the 100 year National Rally at Warrnambool. If for some reason you were unable to commit to this once in a lifetime event, it may not be too late, contact Andrea Casabene now and see what she can do for you.

I must commend Andrea and her team for all the effort they have put into getting this major event up and running in such difficult times. The response from Austin 7 owners has been very encouraging with some 130 plus cars entered. To all the entrants, I know that you will have a rally to remember for many years to come. Please travel safely to and from the event.

At the end of May 27<sup>th</sup> -29<sup>th</sup> we will be conducting our 45<sup>th</sup> Historic Winton. This is a major event for the club and we rely on you the members to make it happen to the high standard that we have set as the benchmark. I am pleased to report that the Friday tour around the Benalla area is back on with a new self guided format. Take some time out of your weekend and join in and have a look for yourself.

We are as usual in need of some support from the members. Please see my article for a ticket controller (on Page 13).

Len Kerwood

2022 when only the best will do. 0419 504 233

Why do they call it a TV 'set' when there is only one?

What are you vacating when you go on a vacation?

## Letters to the Editor

### FIRST NATIONAL AUSTIN 7 RALLY

The Editor has received a number of comments about the article, that appeared in the October 2021 Lightshaft, about what the author, Wayne Styles, purported to be the First National Austin 7 Rally.

That article was repeated in most of the other Austin 7 clubs' newsletters in Australia.

The following article from Bill Sheehan

### THE FIRST NATIONAL AUSTIN 7 RALLY IN OZ

It's pleasing that the Editor corrected that fictional article that in a recent Lightshaft, as many members I've spoken to also believe that History should be Fact.

For the newer members and the Club's archives, here are a few details of the First National Austin 7 Rally that may be of interest for posterity:

Before that, our first Club Austin 7 Rally was suggested by Dale Shaw and the Rally Director was Ken Innes-Irons. Invited were two acquaintances of mine, Leo Drill and Arthur Davey, to be Guests of Honour and Judges.

Leo Drill, previously of the Austin seven baby Health Centre, in Elizabeth St, Melbourne,,attended. But unfortunately Arthur Davey was ill on the day and couldn't make it. Arthur had been Sales Manager of his Melbourne firm that imported the first Austin Sevens in 1923. He was also his brother's riding mechanic in the first Australian Grand Prix in 1928, where their Seven came third in class and 10th Outright. Winner of the best Seven on the day was Alan Esmore with his Ace sports. But this was not a National Rally, even though all, including non-members, were

## Letters to the Editor

invited.

The **REAL** 1st NATIONAL AUSTIN 7 RALLY.

To commemorate the 50th anniversary of the Austin 7 in 1972, the Committee decided to hold a Nation Austin 7 Rally, in Melbourne. Tony Johns headed a group to organise it, others being Dorothy and Graeme Smith, Alan Loughron, Colin Masterson (NSW) and myself. There were others who volunteered their help, including Bev and Graeme Logan. (Apologies to others who I may have forgotten—it was a long time ago!) It was agreed we hold the gathering at Emu Bottom, Victoria's oldest remaining homestead, on a farm at Sunbury. I designed a poster and printed it (unknown to my employer at the time) and Invites and Entry Forms were sent all around Australia. Colin chased up all the Queensland and NSW possibles. Some of the Interstate entries were transported here by him.

As for the starting point, I phoned an acquaintance, Melbourne businessman George Frew and asked his permission to start the cars outside his Old Melbourne Motor Inn. This was a new motel built on the lines of architecture in southern USA). He asked "Why not use the inside of the courtyard?" - so we were happy to comply. In case of bad weather, he offered his covered Car Park around the corner. Plan B was using one of Kings Parkades, owned by Bev. Logan's father.

Entries arrived from all over.

Graham Smith had bought bulk Red and White Wine, the bottling of which was most enjoyable - the Commemorative label was designed by Dorothy Smith.

Saturday involved a short run, followed by Dinner at a Restaurant in St Kilda.

## Letters to the Editor

The Sunday saw the 85 entries (more arrived at Emu Bottom, making a total of 100) head off in convoy up the Tullamarine Freeway.

The judging resulted in Colin Anderson ('29 Holden Fabric Saloon) taking out the Restored Class and my '25 Chummy the Transport Class.. Colin Masterson won Racing/Sports Class. Other awards for Long-distance etc rounded out a most enjoyable day.

The coverage was recorded by the late Roger Shea (he drove his Ruby around the World)

Full details (& plenty of photos by Neil Johannesen, David Lowe, Graeme Logan and Robert Humphreys) appeared in the Light Shaft of December 1972.

### **BILL SHEEHAN**

Editor's note

There was also a Swap Day on the Saturday, organised by Roy Ducat. He also donated a quantity of commemorative posters.

I organised the presence of the Australian Grand Prix Trophy, with the so-called replica of the Arthur Waite car.

That was my first year on Committee, as Editor, although I had served on a number of Sub-Committees before then.

Rob.H.

I'm at a place in my life where errands are starting to count as going out.

## Editor's Ramble

This month's Lightshaft is a special bumper issue, as the Editor's manner of celebrating the year of the 100<sup>th</sup> Birthday of the first of our favoured vehicles.

There seems no doubt that 2022 is that year, but - can a car have a birthday?

It seems that the Austin Board of Directors finally caved in on the production of the car, in late 1921, after Lord Austin had, perhaps secretly, been expediting the design from as early as 1920.

He announced the future production to the Birmingham Motorcycle Club in January 1922, and the first prototype was built in early 1922. Then there was the official launching on 21 July 1922, and perhaps that should be viewed as the car's christening, and maybe the viewing of the new car by the Austin employees at their annual Whitsun carnival picnic day on 4 June 1922 should be viewed as its birthdate.

As we all know a bit of genetic engineering produced a whole family of babies, as it gradually put on weight, got fatter, had cosmetic surgery, was stuffed full of super genes while some were trained for war or toting heavy loads. Others were stuffed with steroids, to break records, sprint up hills or even plough paddocks. Then there were the aquatic versions that either powered boats or pumped water.

As we all know some were stripped bare and exiled off-shore to be outfitted by "colonials".

To add insult, to injury, some were expelled to foreign countries, baptised with foreign names, and some even had their gender reassigned.

But we love them all! ..... Continued Page 10.

## Editor's Ramble

The extended “family” then perpetuated the name of their favourite baby on numerous future generations – a sure indication that our baby has become an icon in its own time.

It seems that many of us would think that their favoured car should, at some time in the near future, “receive a message from the Queen” when reaching 100 years.

Rob.H.



## CLUBROOM GHOST

Is the Club Rooms ghost a phantom greenie, trying to save the world?

The “Ghost” may think that it is saving energy, by crawling under the kitchen sink, and turning off the power to the kitchen sink Hot Water System.

However, the HWS powers up automatically with the light in the kitchen, and is an instantaneous, so only heats water when the tap is turned on.

AND the HWS power turns OFF when the kitchen light is extinguished.

The Ghostbuster

By saving energy we will save the world!

**HELP NEEDED -****HISTORIC WINTON  
Ticket Controller**

Your club is in need of assistance. We have a position of a Ticket Controller for Historic Winton.

This role is only required for a month or two. No need to attend Historic Winton.

**What's Required**

⇒ To act as the control point for the distribution of the paper tickets for the officials and volunteers.

Please note you will be dealing with the key officials who are responsible for their manpower.

Tickets are numbered and a record of the number issued to whom will be a requirement.

Please Contact Len Kerwood 0419504233 to offer your support. Thank You.

**CLUB VISITOR**

If you know of a Member who is unwell or in Hospital please contact Bruce Walker, our Club Visitor. He will visit or send a card to the Member.

Contact Bruce on [brucewalkerartisan@gmail.com](mailto:brucewalkerartisan@gmail.com)

9807 1729 or 0409 410 700.

## MEMBERSHIP REPORT

We welcome new member Craig Jones from Marco Island, Florida, USA. Craig is formerly from Tasmania as is his 1928 Chummy. The Austin 7, that at some stage had the back cut out to make a “pickup“, has been in the family since about the 1940’s but has been off the road since the mid 1950’s. Craig can be seen towing the Austin 7 in Florida behind his E Type. Not your usual tow vehicle.

I would remind members that Junior Associate membership is for a child or grandchild of a Full Member and must be aged under 21, and be a dependent child. Date of birth will be required for all Junior members in the future.

Russell Dickson

## SPARES

*PLEASE come to Spares **with a list prepared beforehand**, to speed up being served, and enable compliance with our COVIDSafe Plan.*

*All attendees must be double vaxxed.*

*Please be prepared to follow the current COVID restrictions.*

*Only Spares Committee Members may enter Spares, PLUS*

*Up to TWO buyers of Spares, as invited by the Spares Committee Members.*

***PLEASE** When you visit Spares try to make all your purchases in **a single transaction**. This makes the book-work much easier for our volunteers, and respects other members who also want to make purchases.*

## COMING EVENTS

### PHILLIP ISLAND CLASSIC FESTIVAL OF MOTORTSPORT

Friday to Sunday 11 to 13 March 2022

See the VHRR website for details.

## AUSTIN 7 National Rally 2022

*Are we all excited !*

If you have any  
questions please  
email me

Kind Regards

Andrea Casabene

0417 109 251



The graphic features a stylized whale on a light blue background. The whale is black and white with bubbles coming from its blowholes. To the right of the whale, the text 'Austin Seven' is written in a cursive font. Further right, '100 YEARS' is written in a large, outlined font. Below that is a silhouette of an Austin Seven car. At the bottom right of the graphic, it says 'WARRNAMBOOL National Rally 2022'.

We are excited  
And you are invited!

National Rally  
Saturday 9th April - Thursday 14th April

Celebrate 100 years of Austin Sevens  
whilst exploring this beautiful part of Victoria  
Come have a whale of a time in Warrnambool!

Enquiries: [2022rallyinfo@gmail.com](mailto:2022rallyinfo@gmail.com)

## COMING EVENTS

### HOT CROSS BUN RUN GOOD FRIDAY - 15 APRIL 2022

Annual Charity Event: Generous donations collected for the Royal Children's Hospital Good Friday Appeal



WHERE - Rosella Oval / Picnic Area – Braeside Park

Enter Braeside Park from Lower Dandenong Road.—Rosella Oval is the last oval on the left hand side before the exit back onto Lower Dandenong Road. Please note this is a ONE WAY circuit.

**Lower Dandenong Road, Braeside. Melway Map: 88 E8**

Come early to try to park all our the cars together as a club.

Look for the Austin 7 flag banners.

WHEN Time. 9.00am till 2:30pm

BYO Picnic chairs and tables, Lunch and drinks, sunscreen.

No Alcohol is permitted.

The organisation of this event is shared by the Veteran Car Club Vic (VCCAV), Vintage Drivers Club (VDC), Classic & Historic Automobile Club of Australia (CHACA) and the Austin 7 Club Inc. This year will be hosted by the Austin 7 Club Inc.

*Since many of our Club Members will be driving home from the National Rally, we expect a very much reduced attendance, and have advised the organisers.*

## COMING EVENTS

### OST 1 - Woori Yallock - Sunday 1 May 2022

**1805 Warburton Highway.** Take the Warburton Highway (B380) to the traffic lights in Woori Yallock. The site is a further 2.0 km (approximately) on the left along the Warburton Highway opposite Lusatia Park Road (follow the signs)



FLORENCE  
THOMSON  
*Tour*



FRI 29TH APRIL TO SUN 1ST MAY.

Attention ladies, it's time to polish up your classic vehicle and join the Association of Motoring Clubs (AOMC) /RACV on the 2022 Florence Thomson Tour to celebrate the contribution women have made to the motoring world.

Travel the historically interesting roads of the Victorian goldfields passing through Maldon, Castlemaine, and North Harcourt.

Tour the historic Buda house and gardens, enjoying a buffet lunch there. Visit the interesting Morris Garage collection at North Harcourt. Celebrate your successful rally with a dinner at the Lakeside Motel, and finally show off your pride and joy at Bendigo Pottery on Sunday morning.

**COMING EVENTS****OST 2 - Glenburn - Sunday 15 May 2022**

From the Glenburn Roadhouse continue north on the Melba Highway for about 6.5 kms . Turn right into Murrindindi Road., travel approximately 2 km, turn right into Old Murrindindi Road , follow for about 2 km, property is on the left

**B40 #2****Rally****13th-15th May 2022**

Entries are now welcomed for those drivers under 40 in cars pre 1940 for the B40 Rally #2 to Central Victoria



**COMING EVENTS****HISTORIC WINTON - 2022**

**Saturday 28 May 2022 to Sunday 29 May 2022**

**Date to be confirmed**

**HELP WANTED - HISTORIC WINTON**

With the Austin 7 National Rally happening in April 2022, and some retirements from the Sub-Committee, we are short of volunteers.

Many of the tasks do not need lots of meetings, and for some you do not need to attend Historic Winton.

There will also be someone to train you in the task, and give you assistance when required.

There are a wide variety of tasks, some short-term.

Please contact one of the following:-

Len Kerwood

0419 504 233

[president@austin7club.org](mailto:president@austin7club.org)

Robert Humphreys

0427 772 281

[editor@austin7club.org](mailto:editor@austin7club.org)

**OST 3 - Lilydale - Sunday 5 June 2022**

**70-80 Leonard Road.** From Lilydale travel east on Maroondah Highway for approximately 4 km , turn right into Ingrams Road, travel 1.7 km turn right into Leonards Road, property on left under power line, look for OST signs.

## COMING EVENTS - HELP WANTED

### **BORDER RUN – PORTLAND 11,12 and 13 June 2022**

Our Border Run is happening (third time lucky). In our 100<sup>th</sup> year it is a great opportunity to make the most of our cars, that have largely been mothballed over the past two years. With many of the cars already being transported to the Warrnambool National Rally, there are local investigations in place to securely store cars after the National Rally in the town, so they can travel the short distance to Portland for the Border Run (more details next month). All are very welcome.

As detailed in the previous Lightshaft, we are staying at the Richmond Henty Hotel Complex, where we have a conference room, restaurant and ample trailer parking. Accommodation and all meals are included in the price for this event (which are unchanged from last year) and the various pricing options are detailed on opposite page:

Please call, text or email us to select your pricing option and room type as rooms are limited. We will require a \$100 deposit to confirm your booking.

Please make the deposit payable to:

Austin 7 Club Inc

BSB 083 323

ACC 811 316 316

Description: Your Name and BR22

We look forward to your company on this event.

Regards, Brian and Glynis Gibbons

Ph: 0418508611 or 0427837555

Email: [secretary@austin7club.org](mailto:secretary@austin7club.org)

## COMING EVENTS

Room-Type	Number-Sleeps,-Type-of-Beds	Price-- Doub le	Price- per- Single	Additio- nal-Cost- Per- Person- (>12yr)	Lunch- (\$11- p/p- approx)
Budget-Room	3-(Queen+Single)	\$410	\$315	\$165	
Standard-Room	3-(Queen+Single)	\$519	\$424	\$165	
Standard-Room	3-(Queen+Single)	\$519	\$424	\$165	
Standard-Room	3-(Queen+Single)	\$519	\$424	\$165	
Upper-Level- Deluxe-Room	3-(Queen+Single)	\$538	\$443	\$165	
Upper-Level- Deluxe-Room	3-(Queen+Single)	\$538	\$443	\$165	
Upper-Level- Deluxe-Room	3-(Queen+Single)	\$538	\$443	\$165	
Walk-In-Room	3-(Queen+Single)	\$538	\$443	\$165	
Walk-In-Room	3-(Queen+Single)	\$538	\$443	\$165	
Walk-In-Room	3-(Queen+Single)	\$538	\$443	\$165	
Walk-In-Room	3-(Queen+Single)	\$538	\$443	\$165	
Walk-In-Room	3-(Queen+Single)	\$538	\$443	\$165	
Walk-In-Room	3-(Queen+Single)	\$538	\$443	\$165	
Walk-In-Room	3-(Queen+Single)	\$538	\$443	\$165	
Upper-Level- Queen-Room	2-(Queen)	\$538	\$443		
Upper-Level- Queen-Room	2-(Queen)	\$538	\$443		
Ground-Floor- Deluxe-Queen	2-(Queen)	\$538	\$443		
Ground-Floor- Deluxe-Queen	2-(Queen)	\$538	\$443		
Ground-Floor- Deluxe-Queen	2-(Queen)	\$538	\$443		
Upper-Level- King-Spa-Room	2-(King)	\$559	\$464		

**COMING EVENTS**



*NOT in 2022 !!!*

*“Just-mid year gathering “*

*noon 17<sup>th</sup> July 2022 at:*

*Baxter Tavern*

*117 Baxter -Tooraddin Road*

*Baxter Vic 3911*

*36 spaces booked in the bistro - order and  
pay from the Bistro (less 20%) & Bar*

**Intention to attend asap --->>>**

**[socialsecretary@austin7club.org](mailto:socialsecretary@austin7club.org)**

## PAST EVENT

### Progressive Lunch

A big thank you for the 40 aspiring members attending a not so normal Progressive Lunch

By the time we had had morning tea as self catered at Le Page Park and starting catching up face to face the main lunch moved to our Club Rooms

- ◆ Rob and Ivy undertook bbq duties with gusto
- ◆ David Finn undertook oven duties for finger food
- ◆ Helen and Judy Finn directed table services with aplomb

By now we had settled on 38 attendees due to apologies for Bev and Joan

I had been worried about the amount of food and had doubled up in some areas before lunch - lucky me!!!

#### TALLY

- ⇒ 48 sausages and bread - gone
- ⇒ 12 hamburgers - gone
- ⇒ 80 party pies and sausages - gone
- ⇒ 36 quiche - gone
- ⇒ 2 plant based burgers - gone
- ⇒ 3 enormous cheesecakes - gone
- ⇒ Numerous packaged biscuits - gone
- ⇒ Soft drinks - gone
- ⇒ Wine - gone
- ⇒ Tea and coffee - gone

All in all an excellent day” Ron Crellin Social Secretary 2022

## OUR AUSTIN 7s

### Waite engine – prototype Super Sports - Tony Johns

Hello Members,

Following the very succesful HAS presentation from Courtenay Rumble, A7 Clubmember, Tony Johns has added some information on Captain Arthur Waite's GP winning Austin 7 engine.

"Many thanks for the very interesting presentation on your 1923 chassis.

I thought you may be interested to see some of the special casting numbers on the engine I used in my Austin 7 "Ulster'."

Attached are some photos of the ex-Captain Arthur Waite's 1928 Phillip Island AGP winning crankcase. We know the car sent out by the factory was one of the prototype Super Sports. I owned this engine for many years before swapping the 8 stud crankcase to Graeme Steinfort.

I combined the rest of the castings, the drilled steel timing gears; with one less tooth on the supercharger drive gear than standard production Ulsters. The camshaft and rev counter drive with an original 10 stud crankcase I purchased from England."

- 1) Showing the condition of the 10 stud motor when it was purchased from John Miles UK. Note the deeper section below the engine mounts, and if you look closely the pressure fed oil bottle on the starting dog.



## OUR AUSTIN 7s

2) Col Masterson holding the special inlet manifold. The bare crankcase in front is a later production 9C supercharged crankcase. The extra threaded holes on the side of my crankcase were put there later to mount a longer #5 Cozette supercharger.



3) Water Pump cover also has a SP number. The inlet manifold fits on standard long 1/4" studs.



## PAST EVENT? - PUB CRAWL deferred

4) Opposite (Magneto) side of the crankcase.

5) SP numbers clearly visible.”



Below is a link to Tony's very interesting and well researched continuing series 'Austin Seven racing in Australia from 1928' on the Autosport forum.

<https://forums.autosport.com/topic/215085-austin-seven-racing-in-australia-from-1928/?view=getnewpost>

We hope you like this extra Austin 7 historical information.

Regards, The Committee of The Austin 7 Club.

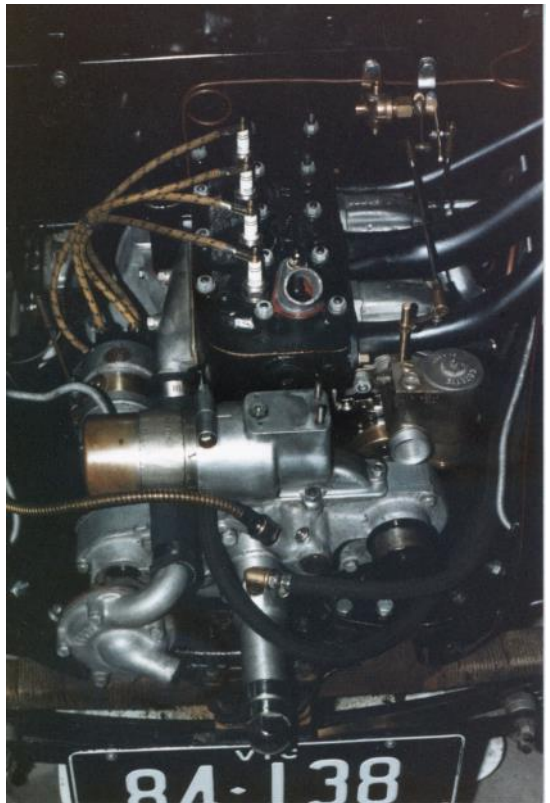

## WHERE IS IT NOW?

***One of our Club Members is trying to trace a car that he owned.***

I am trying to trace a vehicle I once owned in the late 60's.

I sold the car in uncompleted state since I was moving to South Africa to take up a senior management position and there being little likelihood that I would be returning to Australia in the foreseeable future at that stage.

The following details may assist, namely:

1925 Austin 7 chummy with pram hood

At the time of sale the car consisted of the following:-

- ⇒ Complete chassis with motor & gearbox in place
- ⇒ Partially completed body ready for final panel fitment
- ⇒ Seat frames
- ⇒ Instruments in dashboard
- ⇒ All parts to complete the car, including a magneto and all other components
- ⇒ Spare "short" engine in a wooden box

The car was nor registered and no details of original registration were known

At the date of the sale I was living in Moomba Avenue, Seaford, Victoria

Buyer: unknown, but I do recall that he was also a VDC member at the time.

I would dearly like to know what happened to this charming little car and, possibly, explore the possibility of buying it back.

Bernard Snoodyk 0424 598 787

## **CARING FOR YOUR BABY**

### **Why won't my Dynamo generate?**

#### **Case #1.**

With no charging happening, the Chummy owner considered wiping the oil from the CAV DEL dynamo's commutator, but on recommendation, considered the better way was to remove it so as to completely check it out on the work bench.

On inspection I found the brushes were in good order, but inspection of the brush holders revealed a loose brush holder and another holder requiring realignment. Also, a noisy Commutator End bearing was found once the brushes were removed. The armature passed the Growler test that tests for short circuits in the commutator but failed when tested in the Drop test for continuity, as there were five open circuit windings.

This was remedied by tracing by voltage drop, to locate the faulty connections. With the aid of a heavy soldering iron, all faulty connections were then re-terminated. The Growler, Drop and ground tests then passed ok.

The new CE bearing was fitted and the dynamo reassembled. The motoring test by connecting D and F terminals of the dynamo together to +6 volts was done as a first check to see if there were any problems still present, since the reassembly was done.

The dynamo was installed on a dynamic tester and run up to speed to check the output using a battery, and a dummy load and setting the third brush for the current limited (conservatively) to 5 Amps at the correct range of output voltage (about 7V).

## **CARING FOR YOUR BABY**

### **Why won't my Dynamo generate?**

#### **Case #2.**

This Chummy's CAV DFL dynamo had been cleaned and reassembled previously. The owner had already tried the motoring test with 6 volts DC applied to the field and armature joined together. The dynamo rotated correctly. Unfortunately, on installation in the car, no output was showing on the Ammeter.

After checking that the wiring was correct, the next check was using a moving coil voltmeter to see a very low output voltage from the D terminal. By touching a wire to the field terminal from the 6 volt battery the output voltage was able to rise up to 6 volt. Energising the field coils temporarily created an increase in field magnetism. Proof the dynamo could generate an output voltage.

The symptom was a very weak output voltage from the dynamo D terminal. (For some theory, the dynamo armature is only creating a very low output due to weak residual magnetism stored in the iron field poles of the dynamo. The cut-out regulator coil wired to the D terminal was loading down the small current being generated, preventing the voltage increasing enough to close the cut-out relay contact. The voltage must be at approximately 7 volts.)

The remedy was to "Flash" the field. With the field to the wire disconnected. The +6 volts from the battery was flashed onto the field terminal about three or four times for a few seconds each time. This creates an increase in the magnetism in the iron field poles. (The same theory as re-magnetising a magneto which requires an extremely strong field in its poles.)

## **CARING FOR YOUR BABY**

### **Why won't my Dynamo generate?**

The reason the field flux was lost is that magnets require a “keeper” to be kept across the North South poles or the magnetic flux decays. This is very important on magnetos when they are dismantled. In this case the armature being removed had allowed the field to weaken. The field also weakens on some dynamos that haven't been used for a long time or have been dismantled.

With all the wiring reconnected, on testing in the car, the dynamo now worked correctly. The cut-out relay was confirmed to pull in at about 7.3 volts as the engine sped up and to drop out as the engine returned to idle. Opening of the cut out occurred at about +6.5 volts so as not to drain back from the battery. Observing for correct charging at the control panel ammeter, one can see a jump up to charging as the revs were increased then as the engine was returned to idle, a slight discharge prior to flicking off. The third brush position was set to limit the charging current to a conservative 4 amps.

**John Shiells**

#### **LIGHTSHAFT ON THE WEBSITE**

*You can receive the whole of the magazine in glorious technicolour - if you are happy with only receiving your magazine in this form, then please let the Membership Secretary know.*

*Rob. Humphreys*

*Even if you want a hard copy, consider updating your email, and requesting an electronic copy as well.*

## Austin Seven Differential Bearings

The drawing of the New Pinion Mounting first appeared in Austin Seven Journal for March April 1931, page 67 under 'Renewing Axle Bevels and Crown Wheels'.

(This drawing was also shown in the Austin Companion,)

### Rear Axle Bearings

Commencing from chassis No. 118,501 (September 1930), all cars are fitted with a rear axle in which a modified form of bearing mounting for the bevel pinion is incorporated. The orthodox Thrust Bearing hitherto mounted behind the bevel gear is now dispensed with, and replaced by two ball bearings of the double purpose type, which are housed in the rear end of the torque tube, and held in position by means of a screwed distance piece. There is a new bevel pinion having a threaded portion on the shaft to take the bearing retaining nut.

\* AC BEARINGS HAD NAKKON OUTER RINGS

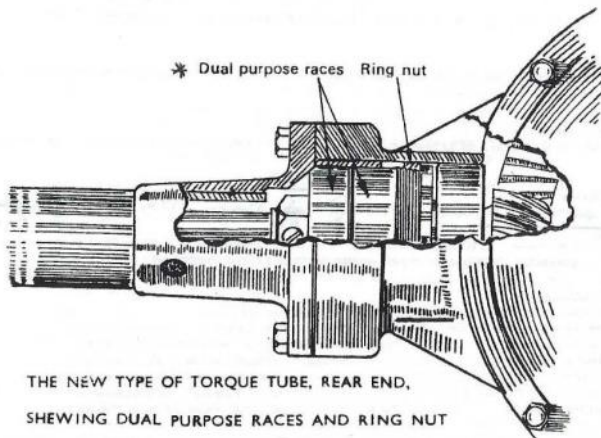

The drawing shows the first AC Bearing mounting with a 'Ring Nut' or 'Outer Distance Piece' later changed to a two piece housing (see below) On page 70 of this Journal it quotes "Commencing from Chassis No 118,501 (September 1930) the Angular Contact bearings (or as Austin have it 'Double Purpose type') were fitted. Because they considered the narrow outer ring was standard there is no mention of this rather critical advice !

## Austin Seven Differential Bearings

Page 71 indicates the Bearing Retaining Nut initially used a setscrew lock, changed to a tab washer in January 1931 requiring a flat on the Pinion Shaft (filed on earlier Pinions !).

In the May 1931 issue on Page No 5 and 6 it gives further : the pinion Shaft Thread was changed from right hand to left hand at Chassis 133178 April 1931.

The internal thread in the bearing housing in the Torque Tube and associated external threaded bearing retaining nut (called variously Ring Nut and Outer Distance Piece by Austin) was changed from right hand to left hand from Chassis No 133,313 April 1931.

MAY

### ALTERATIONS IN DESIGN.

#### Austin Seven.

**P**LEASE refer to the alteration in design explained on page 71 of the March-April issue under the heading "Bevel Pinion Bearing Retaining Nut."

We have found one or two cases, in cars made before we used the lockwasher, where this nut has not been correctly replaced when the axle has been taken down for repairs. In the case of any axle that you have to strip for repair or other attention, in which you find one of these early type shafts, the shaft should have the flat added—see accompanying drawing—and the lockwasher should be used. If you have not the facility for grinding on this flat and will return the shaft to us, we will attend to it free of all charge.

In any case, particulars of the car and chassis number of any shaft that is altered in this manner should be sent to us in order that we can amend our records and thus ensure the correct despatch of spare parts at any subsequent date.

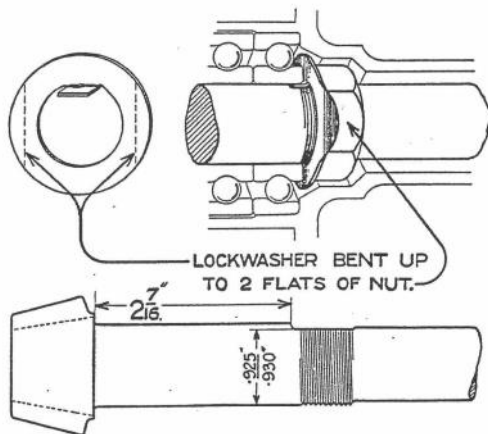

Further modifications have now been made. The bearing retaining nut on the bevel pinion shaft is now made with a left-hand thread, and the shaft is threaded to suit. A modified type of lock-washer is also used, it now being made with a locating tongue which takes up a position between the flat on the shaft and the bore of the inner race of the adjacent ball bearing. The length of the flat on the bevel pinion shaft is extended towards the gear to suit.

(Continued overleaf.)

## Austin Seven Differential Bearings

The Angular Contact Bearings are always mounted Back to Back

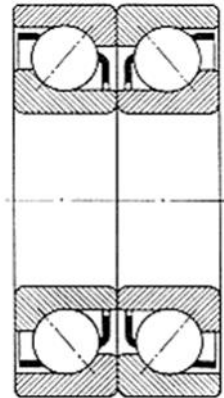

**Back-to-back**

(If incorrectly mounted 'face to face' the narrow outer ring bearings would have 60 thou preload)

The original AC Bearings were mounted with 2 thou axial float, in June 1936 this was changed to 2 thou preload.

We can only obtain non matched bearings now- check to see that with the inner rings clamped together there is a small clearance between the outer rings.

The axial position of the pinion is governed by the outer rings of the angular contact bearings held in the torque tube housing.

As noted all the original AC bearings fitted to the Austin 7 had outer rings  $1/32$ " narrower on the non thrust side compared to the standard width inner ring and fitted back to back on the pinion.

All modern AC Bearings have outer and inner rings the same standard width.

## Austin Seven Differential Bearings

These original Angular Contact Bearings were a 'non standard' SKF ALS 8/RHP LJT 1", with the outer ring 1/32" narrower than the inner ring. The Club Spares have had a quantity of standard bearings machined to suit and packaged as a pair under Part Number 0394a

With the outer ring narrowed by 1/32" on the non thrust side then the pinion is located 1/32" forward on the position it would occupy with a full width outer ring bearing.

The bearing housing is also relieved on the pinion side AC bearing so the pinion radial bearing takes the radial load.

In 1933 the 'ring nut' or 'Outer Distance Piece for clamping the AC bearings was changed to a two piece housing which means the combination of bearing ring width tolerance and housing depth machining tolerance can cause slight end float which must be reduced to clamp the rings

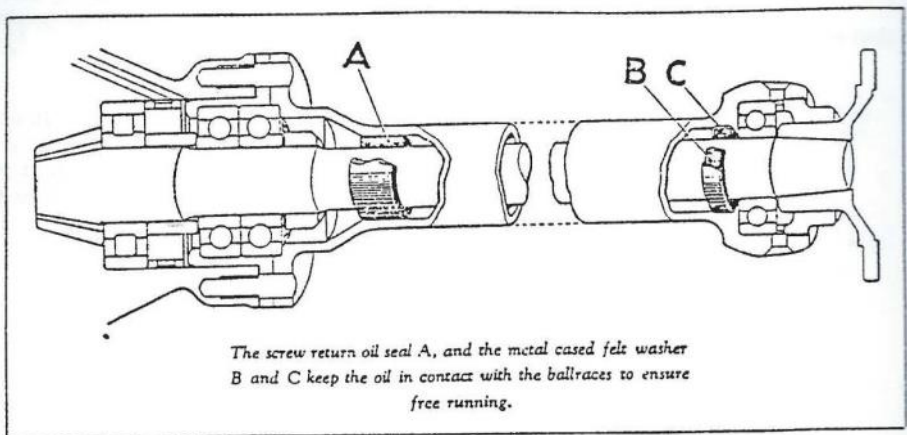

Two Piece Bearing Housing

## A Snatch of Club History - August 1964

Editor's Note:-

When I joined the Club, and for many years after, there was a great interclub competitive rivalry exhibited in a range of events, including Gymkhanas (now called Motorkhana), Road Navigation Trials, Sprints and circuit racing.

The last of these saw the Club introducing and conducting the Six Hour Relay Race, for many years. It was keenly competed by many car clubs, and was based on a complex handicap system, based on the performance of all the cars in each team (usually of four cars).

GEOFF MILLER.

TEMPLESTOWE  
INTERCLUB  
GYMKHANA  
SUNDAY,  
JULY 6th

At last - a fine day at Templestowe! What with the fine weather and a good day's sport, this was a most enjoyable event. Capably organised by Col Marston on behalf of the VSCC, all events went smoothly, in spite of some delays due to faulty timing equipment.

Nine Clubs competed and the events consisted of one timed hill climb, a Slalom on the hill behind the pits, a garaging test in the pits, a dice through the trees on the flat, and a scream through the esses.

The results below are highly provisional, and could quite possibly be changed (let's hope not!). Once again the Club team showed that consistent team effort will beat individual brilliance every time:

Results: (Subject to official confirmation) -

1st	Austin Seven Club Vic.	1798.35 sec.
2nd	Morris 850 Club	1803.80 "
3rd	VSCC (Melb.)	1825.82 "
4th	LCCA	2011.45 "
5th	VADC	2106.82 "
6th	VSCC (Alexandra)	2113.11 "
7th	AMSC	2133.21 "
8th	Peugeot	2164.00 "
9th	MUCC	2180.38 "

Best individual performances:

Event 1:	Hill Climb	R. Hume	VSCC	61.69 sec.
"	2: Slalom	I. Wells	AMSC	
"	3: Garage	A. Hall	VADC	
"	4: Trees	G. Knox	AMSC	
"	5: Esses	R. Hume	VSCC	

A few members of the Club went along to prove to all the superiority of the Austin Seven in mud. However, although I haven't any official results to date, it looks as though the event was won in convincing

## A Snatch of Club History - April 1965

F. A. H.

### AUTOCROSSE - MONDAY MARCH 8

A good entry of some 20 cars was received, and David Lowe set up his usual fast and hairy course. The Austin 7 Racing Class was won convincingly by Trevor "Old King" Cole in Smoky Mary, while another Smoky Mary, this time a Chummy driven by Nigel Tait, won the Austin 7 Touring Class.

Neil Johannesen had an off day, and was observed trying to push his ailing Chummy up the final slope. He was last seen, muttering strange things like "no compression, oiling plugs in all cylinders". The rumour that he is fitting glow plugs to eliminate plug oiling is definitely not true.

Cooper Minis took the first five places in the Other Cars Class, the eventual winner being Neil Pollock, in 41.03 just ahead of Doug Watson. In this Class John Bowring (hotly pressed by his co-driver) had quite a battle with Mick Allan, but Mick won in the end in 44.87.

One gentleman (who shall be nameless), turned on a breath-taking performance when he inverted his Austin 7, and joined the ranks of the Roly Poly Club. Altogether a very enjoyable day, spoilt a bit by very windy conditions.

Special thanks go to the organisers, Geoff Taylor and David Lowe, and the Timers Frank Walter and Ken Innes-Irons, whose help is invaluable in running these enjoyable events.

Thanks also to Mr. Arch Mason for the use of his property for the event.

NIGEL TAIT.

#### RESULTS:

<u>Austin 7 Racing</u>		<u>Austin 7 Touring</u>	
1. T. Cole	43.20	1. N. Tait	47.72
2. P. Pretty	46.30	2. J. Bowring	49.66
3. K. Logan	51.07	3. N. Johannesen	56.72
4. N. Posher	56.47		
<u>Other Cars - Over 1600cc.</u>		<u>Other Cars - Under 1600cc.</u>	
1. A. Lowe	Holden 43.44	1. N. Pollock	C/Mini 41.03
2. D. Shaw	TR4 43.88	2. D. Watson	" 41.47
3. M. Reddan	Holden 49.41	3. B. McInnes	" 41.88
4. R. Stevens	Holden 50.43	4. S. King	" 42.36
		5. G. Taylor	" 42.79
		6. L. Sampson	Sprite 43.37
		7. M. Allan	VW 44.87
		8. P. Turner	Sprite 44.99
		9. J. Bowring	VW 45.25
		10. N. Tait	VW 45.34

APRIL 1965.

The "LIGHT SHAFT"

RGE Three

<u>Other Cars - Under 1600cc (Ctd.)</u>			<u>Other Cars - Under 1600cc. (Ctd)</u>		
11. D. McInnes	C/Mini	45.83	16. R. Cowley	Prefect	48.85
12. A. Johns	AusTen	46.71	17. L. Coleman	Herald	49.17
13. F. Walter	"	46.99	18. K. Innes-Irons	Sprite	49.67
14. G. Taylor	"	47.57	19. B. Ash	Hillman	51.37
15. S. Morris	Renault R8	47.74	20. F. Kinley	Ford 10	51.98

Four Austins entered for this, the first road race meeting on the Club Calendar. One was a

**To all of you who have a car under the Club Permit Scheme.**

**Check your date of EXPIRY of your Permit.**

**ALSO check ALL details - including expiry date, addresses etc.**

**When paying ALWAYS retain your receipt.**

**Keep a scanned copy of your receipt with your logbook.**

**Renewal Notices are a bit flakey, as it appears that VicRoads is becoming more reliant on YOU having a**

**My VicRoads Account.**

**A My VicRoads Account also assures you of an email reminder for renewal.**

**Check your My VicRoads Account to ensure that your CPS cars appear**

**THE AUSTIN 7 CLUB ROOMS AND CLUB SPARES  
are located at**

**UNIT 8/9, 19-23, KYLIE PLACE, CHELTENHAM NORTH.**

**All correspondence to the Secretary:**

**Austin 7 Club Inc. P O Box 462, Moorabbin. Vic 3189**

***Please do not send mail to clubrooms***

Spares are open:-

M.G.M. from 7.30 p.m. to 8.00 p.m. sharp

H.A.S. from 7.30 p.m. to 9.00 p.m. and between 12:00 p.m. and 2:30 p.m. on the Saturday following the M.G.M. (or the following Saturday if the former clashes with a Club Event)

Spares can be ordered by mail from:

Janne and Robert Humphreys, 27 Peters Drive, Cheltenham Vic 3192

Or [mailorderparts@austin7club.org](mailto:mailorderparts@austin7club.org)

## SUB-COMMITTEES 2022

**HISTORIC WINTON SUB-COMMITTEE**

Co-Chairs - Peta Lee —Secretary of the Meeting,  
Entry Secretary & CoChair, Len Kerwood CoChair,  
Noel Wilcox, Tony Press (Minutes), Mike Belcher,  
Colin and Maria Cheesman, Paul Goethel, Robert  
Humphreys, Faye Stevens, Ron Crellin, Alan Barnes,  
Leanne Goethel, Yolanda Filip, Graeme Logan, Bruce  
Rogers, Greg Drummond

**HISTORIC SPRINT**

Secretary & Entry Secretary – Phil Fitton,

**OST SUB -COMMITTEE**

Chairman – Grant Della, Treasurer: Leanne Coakley,  
Sites Contact: Stephanie Cox, Cooper Schweiger,  
Jason Stock.

**SPARE PARTS SUB-COMMITTEE**

Graeme Logan (Spares Coordinator), Neil Rickard  
(Spares Treasurer), Dennis Hourigan, Graeme Burbidge,  
Robert Humphreys, John Shiells, John Neve, Ted  
Thompson, Mark McKibbon, Brian Gibbons, Bruce  
Shearer, David Easton, Tony Press (Minutes)

**SPARES MAIL ORDERS**

[mailorderparts@austin7club.org](mailto:mailorderparts@austin7club.org)

Robert Humphreys (03) 9583 6316

**CLUB VISITOR**

Bruce Walker 9807 1729, 0409 410 700

**PUBLICATIONS and ARCHIVE SUB-COMMITTEE**

Robert Humphreys, John Neve, Robert Taylor, Allan  
Tyrrell, Tony Press, Archive Curator—David Easton

**LIGHTSHAFT MAIL OUT SUB-COMMITTEE**

Manager - Russell Dickson, John Fatouros, John  
Shiells, Robert Janne & Fiona Humphreys, Lyn Innes-  
Irons, David & Katrina Easton

**URRRS EVENTS COORDINATOR**

John McMillan

**CLUB LIBRARY**

David Easton

**CLUB PERMIT OFFICER**

Russell Dickson, Robert Humphreys (Deputy)

**TECHNICAL ADVISORS*****Model & Parts Identification, Bodywork & Literature***

Bill Sheehan 0435 582 294

Tony Press 0409 948 430

***Mechanical and Engineering***

Tony Press 0409 948 430

***Racing and Special Construction***

David Lowe 0458 172 494

***O.S.T. and Motorkhana***

Grant Campbell 9787 3640

***Spares Engineering Review***

Brian Williams, Russell Dickson, Denis Hourigan,  
Tony Press (minutes )

**RACING SPOKESMAN**

Phillip Hallo 0413 185 576

Noel Wilcox 5428 2689 AH

**Motorsport Australia State Council Delegate**

Gary Hawkins 0459 135 496

**MA HISTORIC MOTORSPORT PROMOTERS GROUP**

Noel Wilcox

**WEB MASTER** Tony Press 0409 948 430

**TIMING TEAM SUB-COMMITTEE**

Daniel Morling, Gary Hawkins, Geoff Taylor,  
Stephen Harrison

**AOMC DELEGATES**

Len Kerwood and Robert Humphreys  
alternate John McMillan

**FEDERATION DELEGATES**

Noel Wilcox &/or Remote Member as agreed

**CLUB BUILDINGS OWNERS CORPORATION DELEGATES**

John Shiells, Robert Humphreys, John McMillan

**COVID19 Event Controllers**

Two vacancies

**AUSTIN 7 CLUB INC. - COMMITTEE 2022**

<b>PRESIDENT</b>	Len Kerwood	president@austin7club.org	9435 2544
<b>TREASURER</b>	Paul Goethel	treasurer@austin7club.org	0412 534 131
<b>SECRETARY /VICE PRESIDENT</b>	Glynis Gibbons	secretary@austin7club.org	0427 837 555
<b>MINUTE SECRETARY</b>	Tony Press	minutesecretary@austin7club.org	0409 948 430
<b>PROPERTY OFFICER</b>	John Shiells	propertyofficer@austin7club.org	0403 228 559
<b>EDITOR</b>	Robert Humphreys	editor@austin7club.org	9583 6316
<b>MEMBERSHIP SECRETARY</b>	Russell Dickson	membership@austin7club.org	0409 577 215
<b>COMPETITION SECRETARY</b>	Gary Hawkins	competitionsecretary@austin7club.org	(03)5461 4460 0459 135 496
<b>SOCIAL SECRETARY</b>	Ron Crellin	socialsecretary@austin7club.org	9431 0502

**AUSTIN 7 NATIONAL RALLY 2022 SUB-COMMITTEE**

Chair- Andrea Casabene, Peta Lee (Minutes), Robert Baudinette (Treasurer), Graeme & Bev Logan, Tony Casabene, Russell Dickson, Greg Drummond, David & Judith Finn, Peter & Lesley White, Ron & Helen Crellin, Carole & Len Kerwood, Maria & Colin Cheesman, Helen & Michael Shegog.

**THE VICTORIAN CLUB PERMIT SCHEME**

*It is the policy of our Club that owners of Austin 7 Club Club Permit vehicles **MUST** maintain financial membership at all times.*

Your Club Permit Officers are, our Membership Secretary Russell Dickson and Robert Humphreys.

**Remember to plan ahead if you need a Club Permit Scheme application or renewal signed or issued. You will find more detail on the club permit scheme on the Web Site**

**<http://www.austin7club.org/>**

**CREATE YOUR OWN ACCESSORIES**

A7 Accessory 1928

Found the yesterday. Weekly Times 7/1/1928 page 62.

Cheers

Tony Johns

**Austin Parcels Container**

There is room for small articles to be placed in an **Austin** Seven in the gap between the two front seats. To prevent the oddments being jolted by vibration on the floor a shallow tray of sheet metal or plywood **may** be made to fit the division between the seats. A container 12 ins. by 4 ins. and 2 ins. deep is a suitable size, and it **may** be covered with cloth or leather fabric to match the color of the upholstery. Catches **may** be fixed to the top of the tunnel covering the propeller shaft to hold the tray in position, but the cover over the universal joint lubrication nipple must not be restricted.

---

## NEWS FROM SPARES

### **HOW THEY DO IT BACK IN THE U.K.**



Major repairs were needed to the water outlet side of the block due to corrosion and age of one of the cast in bridges. Using an "Austin Seven Workshop" repair kit, I fitted a new frame to give me a functioning bridge (see picture).

(<https://www.theaustinevenworkshop.com>) I am currently in the process of re-building and putting it all back together. A lot of work, but a great deal of pleasure. I will keep you informed of my progress.

Watch this space.

*Robert Wynell-Mayow - courtesy of the Hereford Austin Seven Club Newsletter*

The March Lightshaft advertised the two repair kits for the water manifolds.

The photo above shows the water inlet kit fitted to a block. Our Part #0123r.

The equivalent for the early head to repair the water outlet is Part #0124r

We have recently received additional stock of late Brake Drums and additional stock of 16" tyres.

### **PARKING AT CLUBROOMS**

In the interests of all members could those attending meetings please park only *in the marked spaces*. Please leave the forecourt for *AUSTIN 7s ONLY* and any *handicapped members*, and please make access available for those *delivering or collecting* goods or club equipment.

**DO NOT OBSTRUCT ACCESS TO OTHER UNITS**

**MARKET PLACE**



**FOR SALE**

1933 Austin 7 with  
spare parts \$16,000  
ONO

Imported from New  
Zealand in 2008

In good condition  
but has been  
standing for some  
time.

Registered

Location near  
Anglesea.

Kaye Batson 0418567158

Email: [macbatjw@gmail.com](mailto:macbatjw@gmail.com)

Also see included parts on opposite page.



**MARKET PLACE****FOR SALE**

1937 Austin Big Seven Tourer.  
New tyres and upholstery.

Fully restored.

Comes with the original  
owner's service manual.

Engine no. A1067 Chassis  
no. 9897

Vintage car registration for  
Queensland. In Mackay,  
Queensland.

I am too old to use it now.

Bill Beetham Ph (07) 4957 5493 email [beethambill@gmail.com](mailto:beethambill@gmail.com)

Asking price \$12,000.00 ONO pick up only. (Can arrange transport)



## MARKET PLACE

***Market Place advertisements will normally appear for FREE in two consecutive Lightshafts Editor***

### **FOR SALE**

1936 sports tourer - \$5,000.

Owned for 25 years & I will never get time to restore I,d like to sell it to a club member who is going to restore it.

Garaged all its life it could be described as a Barn Find. The body, built in Adelaide by Holden, I believe is a fairly rare body type.

Engine was rebuilt 25 years ago with new Pistons, rings, rebored, crankshaft ground and new bearings.

There is very little rust and no damage to the body

Bob Curtis Yarra Glen - Phone 0419 506 036



## MARKET PLACE



### Letter to Editor

#### Sale of Ulster special

Failing eyesight has forced Judith and I to curtail our driving and brought realisation that we must pass our, much loved, Austin “Ulster” special to another custodian, and bring a conclusion to more than seventy years of Austin 7 ownership. We request your assistance to make it known to all our friends in the Austin 7 world that the car is now for sale.

We shall attend the forthcoming National A7 Rally in Warrnambool in which the car is entered. It is offered with its custom built trailer and is available for a new owner before, during, or after the Rally. F

ull details of the car are available from us by

telephone at: (02) 9417 3637 , or by email : [richesrandj@gmail.com](mailto:richesrandj@gmail.com)

With our regards, Bob and Judith Riches.

## MARKET PLACE

### FOR SALE

#### 1938 Big 7 Tourer

Old age and health problems now limit me from driving my Austins so they must be sold.

This is a tourer which took us 1,800 km around Tasmania with a club trip in 2010. Since then Austins over Australia at Bendigo and club trips to Ballarat. Features of the car include

- MG wire wheels with spin off hubs and hydraulic brakes
- Digital turn signals and brake lights
- 4 speed gearbox by John Needham with bushes replaced by A40 needle rollers
- RWC and fully registered with AUST7N plates

Price \$16,000 with personalised plates or \$15,600 on club plates. Inspect at Beaconsfield, Victoria.

Contact Alex Smart  
[smartie38@bigpond.com](mailto:smartie38@bigpond.com)

or 9707 5275



## MARKET PLACE

### FOR SALE - BOOKS

- \* Austin A70 & A90 running and maintenance
- \* Design for competition, a 750 club publication
- \* Austin Seven in the Thirties ((Brooklands))

Stewart Edwards      6 Rupert Ave, Mount Stuart TAS 7000

0416 228 664      Stew Edwards <[macme22@me.com](mailto:macme22@me.com)>

### FOR SALE

The Austin Seven and Eight by Staton Abbey,  
published by Pitman, third edition, 1948.in excellent  
condition.      Make an offer.

Peter Stewart      0409 017 788

Pete <[petejs1959@gmail.com](mailto:petejs1959@gmail.com)>

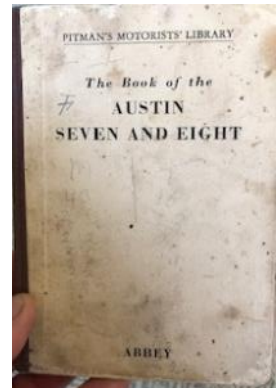

### DISCLAIMER

The Austin 7 Club Inc. (A7C), its Officers and the Committee cannot be held liable for any errors and/or omissions in items that are published in The Light Shaft in good faith. It should be noted that the publication of an advertisement, or expression of views in articles and reports, does not necessarily imply endorsement by the A7C of the advertised product or service, or the views expressed in any articles or reports published in The Light Shaft.

## MARKET PLACE

### **WANTED**

Austin Seven Panel van or Chummy in Going condition.

Graeme Tonkin

Geelong

0400 847 028

### **MAIL ORDER PAYMENTS TO AUSTIN 7 CLUB SPARES**

*Payment for parts is preferred by Direct Deposit.*

Please note Spares Banking Details, located at the bottom of our Invoices.

*Bank branches, if open, are operating reduced hours, making banking cheques difficult, and Credit Card payments, without card, are a risk to the Club and the member.*

**Robert & Janne Humphreys-  
mailorderparts@austin7club.org**

## GEARBOX REPAIRS

To ALL AUSTINs, including F.W.D.

Special Ratios and Standard Ratios

Austin 7 - 4 speed boxes with better ratios from \$1,700

Changeover or yours rebuilt

John or Ben Needham

OLD CAR GEARBOXES P L (03) 9553 3203

**More Photos and news on the website**

**<http://www.austin7club.org/>**

**And you can check for up-to-date information on events and news.**

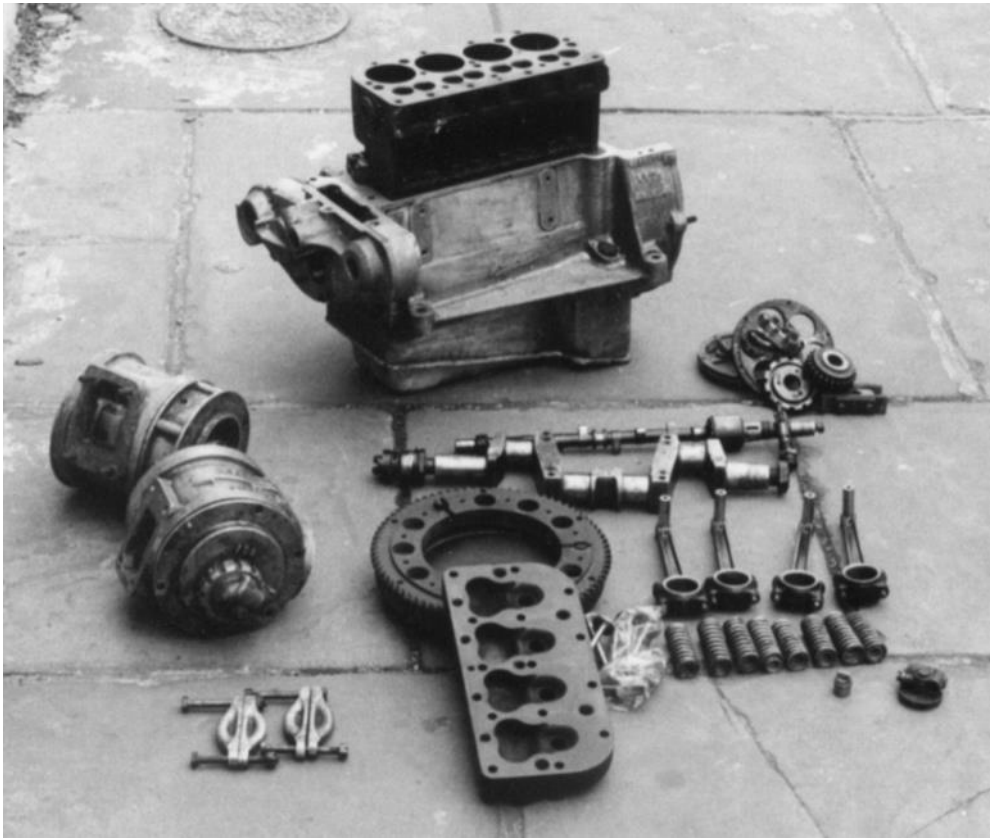

Why show an engine in bits - but these are some of the rarest Austin 7 bits, and with great Australian historical significance.

See story on Page 22. Photo Tony Johns



# 45<sup>th</sup> HISTORIC WINTON

28th and 29th May 2022



[www.historicwinton.org](http://www.historicwinton.org)

Winton Motor raceway, Benalla, Victoria

