

OST Formula Issue: November 2014

1. GENERAL

This formula describes the constructional requirements for cars taking part in Observed Section Trials. Supplementary Regulations for individual events may be added to or subtract from these requirements to meet special cases, but such alterations shall be kept to an absolute minimum.

This Formula shall remain in force for the duration of the year of issue without alteration and will be reviewed annually in the final quarter of each year. Any amendments will be announced by 1st January, and the Formula as amended shall then remain in force for the ensuing calendar year.

Any car constructed to this Formula shall be deemed to comply for three years after a change has been made to this Formula, except where change has been made for reasons of safety.

2. ENTRIES

(i) Each automobile competing in an Observed Section Trial shall carry a crew of two persons, including the driver.

(ii) The entrant and the driver shall hold a CAMS Level 2NS licence as a minimum.

3. ELIGIBLE CARS

Only cars complying with the following description will be eligible to compete:

A four-stroke reciprocating engine with a maximum engine capacity of 1600cc running on commercial fuel. Turbocharging or supercharging is not permitted. Rotary engines are not permitted.

A wheelbase not less than 1900mm for cars with an engine capacity of up to 850cc and 2030mm for cars with an engine capacity between 851 and 1600cc. ([refer Figure 1](#)).

Two wheel drive only

An operable reverse gear

An open body must be fitted with seats for at least the driver and passenger. Hard tops are not permitted.

Minimum width front 1145mm, minimum width rear 1270mm, each measured outside of tyre to outside of tyre at axle centre height ([refer Figure 2](#)).

4. TYPES OF CARS

Competing cars shall be one of only two types:

Front Engined Cars: The engine must be located so that the centre of the foremost spark plug orifice is not more than one fifth of the actual wheelbase to the line rear of a line connecting the centres of the front wheel hubs ([refer figure 3](#)).

Rear Engined Cars: Free engine placement provided the cockpit is located entirely between the axle centre lines and forward of the foremost point of the engine.

5. CONSTRUCTION OF CARS

(i.) General: Each car must be:

(a) Of sound construction and mechanical condition, have no temporary parts, and be maintained in good condition.

(b) Fitted with four wheels only. Duplication of wheels is not permitted. Two driving wheels only are allowed and a differential gear in full and free operation must be fitted between them. Limited slip differentials are not permitted. Steering shall be by the front wheels only, controlled by a steering wheel.

(c) Fitted with a body of adequate strength and workmanship, providing a compartment for the driver and passenger effectively isolated from the engine by a bulkhead suitable and sufficient, in the case of fire, to inhibit the passage of flame. This compartment must be fitted with rigidly supported floor, cases or covers of solid material separating it from transmission shafts and joints, brakes, road wheels and their attachments and linkages to protect the occupants.

(d) On both front and rear engine cars, be fitted with a cover of metal or solid non flammable material, covering and surrounding the engine and fixed by a strap or other fastenings of adequate strength and efficiency ([refer figure 6](#)).

(e) On front-engined cars the bodywork, together with all external equipment, on front engine cars shall not overhang the rear axle centre line by more than one third of the wheelbase measured horizontally from a line connecting the centres of the rear hubs.

(f) On rear engine cars, the bodywork shall not extend rearwards more than 75mm. behind the rearmost part of the actual engine or gearbox or gear change mechanism ([refer figures 4a & 4b](#)).

(ii) Coolant Pipes:

All coolant pipes passing from the front to rear of the car or vice versa, whether inside the cockpit or outside the car, must be protected from accidental contact by driver, passenger and any person outside the car.

(iii) Seats:

Cars must be equipped with securely attached fixed seats within the cockpit, capable of seating the driver and one adult passenger, and adequate for the purpose of retaining them within the vehicle. The rearmost portion of these seats shall not extend to the rear beyond a line connecting the centre of the rear hubs. The seat cushion (that part on which the occupant sits) shall, when uncompressed be not less than 150mm below the top edge of the body side or door, adjacent to that seat. Other seats of any kind may be fitted, but only the passenger's seat, beside the driver, shall be occupied during competition. A handhold for each passenger's hands shall be provided within the confines of the car.

(iv) Safety Harness:

As required by Schedule I of the CAMS manual, a lap type safety harness shall be fitted for each occupant as a minimum. Safety harnesses must be properly mounted and are subject to scrutineers' approval.

(v) Brakes:

Each car must be fitted with effective brakes on at least two wheels. Brakes must remain operative throughout the event. Independent braking systems are permitted on the driving wheels. The operating handles for the braking system must be totally within the confines of the cockpit. (The intention of the above is to prevent contact between the driver's hand and obstacles outside the vehicle).

(vi) Mudguards:

Each car must be fitted at the rear with effective mudguards of solid material which must be securely attached and completely cover the tyre width and one third of the circumference of the wheel. The rear extremities must not be higher from the ground than a horizontal line passing through the centres of the wheel hubs (refer [Figure 5](#)). Front mudguards are optional.

(vii) Exhaust System:

Each car must be fitted with an exhaust system and effective mufflers, so that hot parts are protected from accidental contact (refer [Figure 7](#)). Exhaust systems must be arranged so that exhaust gasses will exit vertically up or down. Noise emission should not exceed 92dB(A) at 3,500 rpm when measured 500mm from and at an angle of 45° to the exhaust outlet.

(viii) Starting Engine:

Each car must be fitted with an effective means of starting, other than via the transmission, i.e. a starter motor or crank handle (which shall remain operable during the event).

(ix) Ballast:

Each car must be free of ballast in any form.

(x) Tow Rope:

Each car must be equipped with an adequate non-metallic towrope of at least 7m in length with a minimum diameter of 17mm. While competing it shall be attached to the car in such a manner as to be readily accessible, without removing any panels or covers. All ropes must be fitted with a standards approved towing hook on one end. The car must have a towing eye provided front and rear marked in a contrasting colour and mounted in a secure fashion as near to the centerline of the adjacent wheels as is practical

(xi) Competition Number Clips:

Each car must be fitted with an effective spring clip fixed to the rollbar so that the competition number is visible above the rollbar from the front and rear.

(xii) Ignition Switch:

Each car must be fitted with an easily accessible ignition switch marked to show "Off "and "On" positions.

(xiii) Battery:

Each car's battery must be securely fixed and covered to prevent spillage of the contents.

(xiv) Roll over protection:

Each car must be fitted with a roll over protection structure (ROPS), the main hoop of which shall consist of mild steel tubing of circular cross section, with minimum dimensions of 44.45mm OD x 2.5mm wall thickness (1.75" x 12 gauge), with longitudinal bracing of minimum 25mm OD x 1.6 mm (1" x 16 gauge). Other material may be used provided it and its dimensions conform to a CAMS Schedule J Type 2 rollbar.

The ROPS when viewed in rear elevation, must cover the full width of the shoulders and be at least level with the tops of the heads of both occupants when normally seated.

(xv) Fuel tanks and Lines:

Fuel vent pipe must exit to the atmosphere at a level lower than the bottom of the fuel tank. The fuel tank cap must seal the tank. All fuel lines must be securely clipped with worm drive type clamps on all joints or connections. Pressure spring clips are not acceptable.

(xvi) Tyres and Rims:

Each car must be fitted with pneumatic tyres on all wheels conforming with the following:

(a) The maximum rim section shall be 5 inches.

(b) Tyres must be in good serviceable condition and have no modification of the manufacturer's tread pattern or any other part of the tyre.

(c) Except as provided in sub-paragraph (f) below, each front and rear wheel must be fitted with one tyre only, inflated to not less than 84 kpa (12 psi).

(d) Tyres must not be fitted with any form of non-skid attachments, studs or chains etc.

(e) The maximum overall width of tyres when the above conditions are fulfilled shall be 165 mm unladen.

(f) Tyres of maximum 175 section, on front engine cars as defined by this Formula, may be inflated to less than 84kpa (12 psi). Tyres may be secured to rims provided that no extra traction is proved by such devices.

(g) The fitment of one supplementary tyre is permitted within each road tyre, provided any such supplementary tyre has a conventional road pattern tread and does not act as an aid to traction.

(h) On front-engined cars only, the fitment of one supplementary tyre is permitted within each road tyre, provided any such supplementary tyre has a conventional road pattern tread and does not act as an aid to traction.

(i) Tyres fitted to the driving wheels must be of standard bitumen road type tread pattern and be available locally.

(j) Undriven wheels may be fitted with road tyres of any pattern, but tri-rib tractor type tyres are prohibited.

(k) All tyres must be approved in writing by the Observed Section trials Sub-Committee and this approval should be obtained in writing before tyres are purchased. Tyres approved by the OST Sub-Committee shall remain approved for a period of three years from the date of initial approval, or of annual re-approval.

(l) Tyres approved by the OST Committee for use in events from May 2012. List of Tyres [Click here](#)

Notes:

1. Additional tyres will be added to the list a minimum of 30 days after the new tyre is approved by the OST committee. This is to allow a reasonable time for all competitors to evaluate the new tyre.

2. The intention is to include all tyres currently in use. If you have a tyre that is not on the list, please contact the OST Committee before the end of the 2009 season.

(xvii) Signs on Cars:

- a) Each car may carry the name, occupation and telephone number of the driver and the name of the passenger, displayed on the sides of the car in characters no more than 100mm high.
- b) Each car may carry a name, providing that it does not advertise a sponsor, product or service.
- c) Each car may carry signs or stickers of a motoring nature.

Organisations or individuals wishing to offer support or sponsorship for this sport are invited to contact the OST Sub-Committee and request approval.

For further information regarding formula or coming events please contact any of the [OST Committee](#):

(xviii) Fire Extinguisher:

Each car must be fitted with a securely mounted fire extinguisher complying with Schedule H Section 3 and 4 of the CAMS manual of Motor Sport.

STANDING SUPPLEMENTARY REGULATIONS - OST

For current SSR refer to the Austin 7 Club Inc. website.

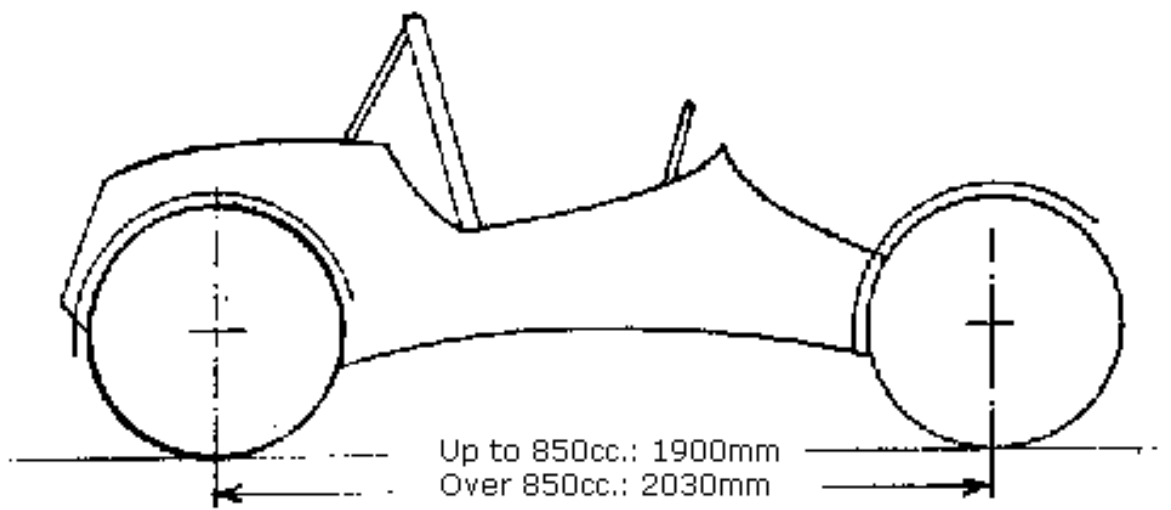

Minimum Wheelbase

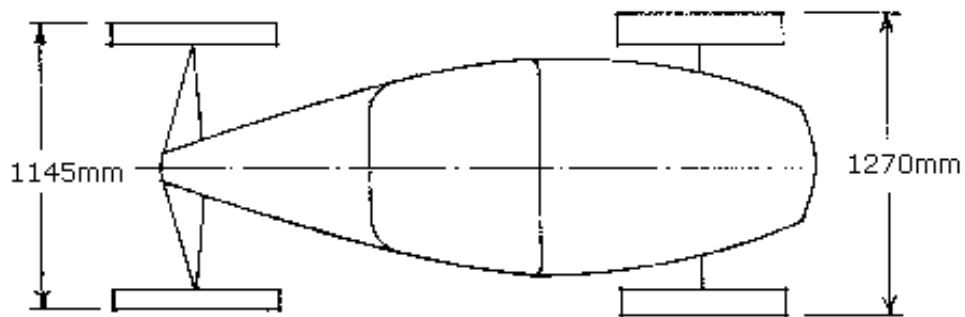

Minimum Track Width

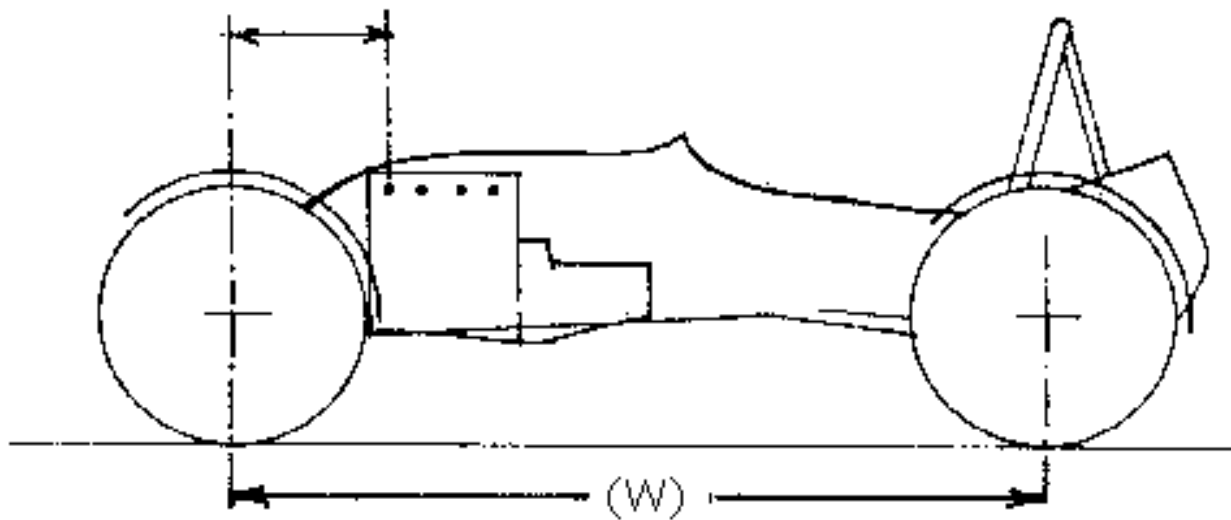
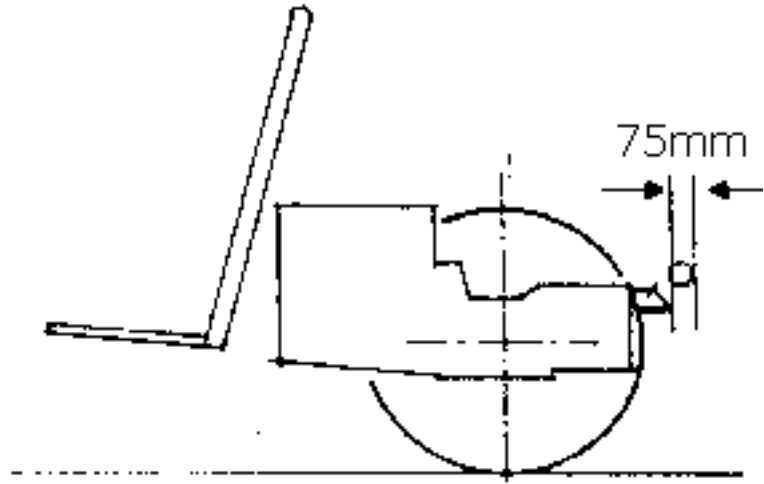
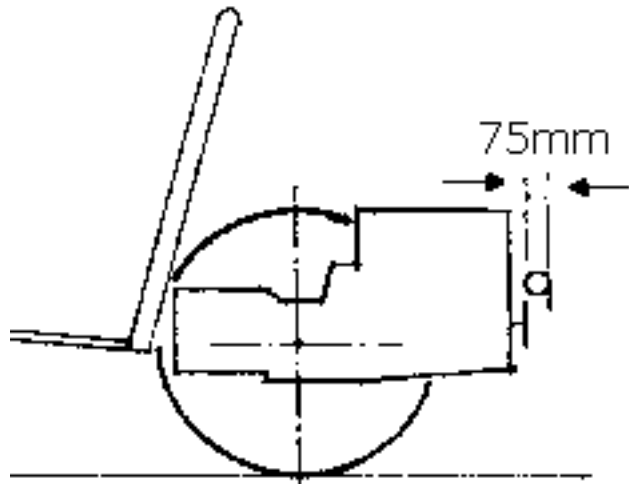

Figure 3. Engine Location - One fifth of wheelbase (W below) - Maximum



Figures 4a & 4b. Maximum Overhang (Rear Engine)

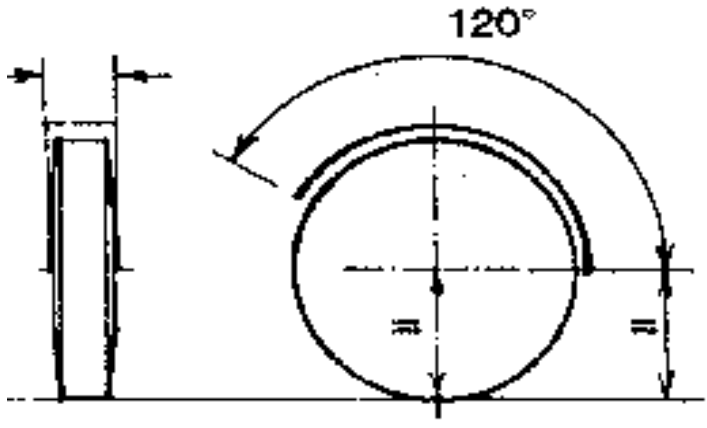

Figure 5. Rear Mudguard - Mudguard to cover tyre width

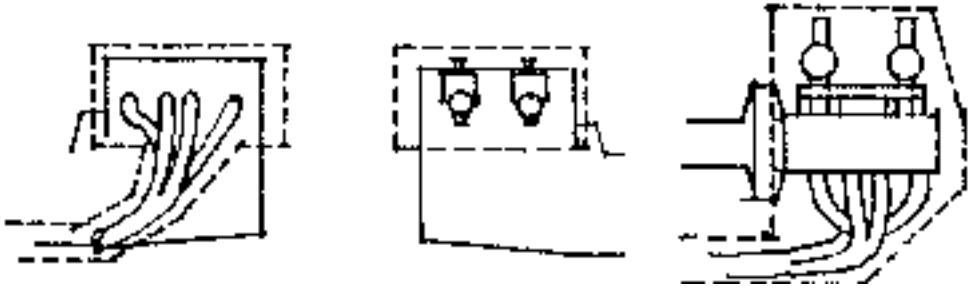

Figure 6. En

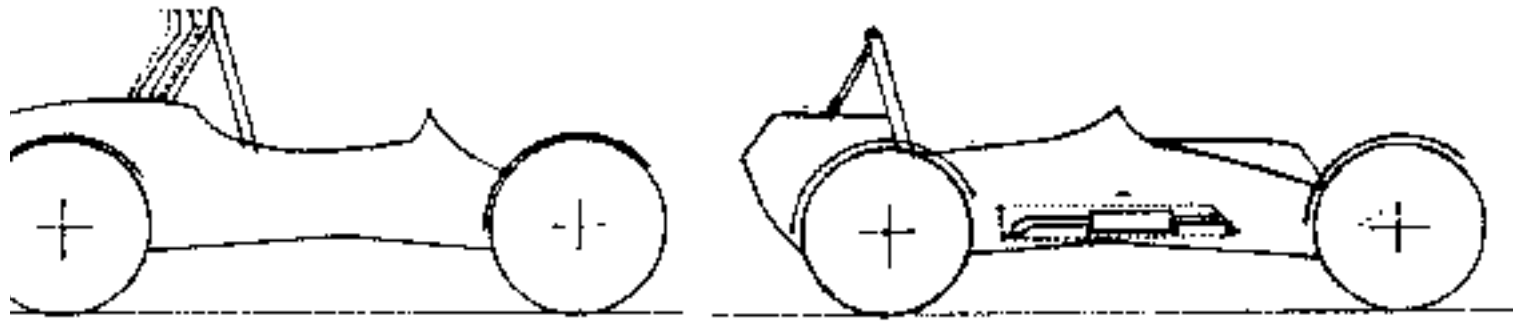

Figure 7. Exhaust Prot